

IN-PRESS

Industrial Style Digital Pressure Meters and Controllers

> Introduction

Bronkhorst High-Tech B.V., the European market leader in thermal Mass Flow Meters/Controllers and Electronic Pressure Controllers, has many years experience in designing and manufacturing precise and reliable measurement and control devices. With a wide range of instruments, Bronkhorst offers innovative solutions for many different applications in many different markets. The instruments are made to customers' specification, in various styles, suitable for use in laboratory, industrial and hazardous areas.

> IN-PRESS series for industrial environments

The digital electronic Pressure Meters and Controllers of the IN-PRESS series are of rugged design (IP65) for use in pilot and production plants in industrial environments or even Zone 2 hazardous areas, with optional ATEX Category 3 approval. The instruments have a well-proven compact thru-flow design and are available in pressure ranges from 2...100 mbar up to 8...400 bar, both in absolute and relative (gauge) pressure. The pressure controller performs with high accuracy and repeatability and should be specified for forward or backward pressure control.

> State of the art digital design

The IN-PRESS Pressure Meter/Controller is equipped with a diaphragm type piezoresistive pressure sensor and a digital pc-board, as standard offering high accuracy, stability and reliability. The main digital pc-board contains all of the general functions needed for measurement and control. In addition to the standard RS232 output the instruments also offer analog I/O. As an option, an integrated interface board provides DeviceNet™, PROFIBUS DP, Modbus or FLOW-BUS protocols. The latter is a fieldbus based on RS485, specifically designed by Bronkhorst for their mass flow and pressure metering and control solutions.

> Pressure Controllers for every application

The pc-board of an IN-PRESS Pressure Meter features integrated, adaptable PID control for fast and smooth control of any electronically driven valve. With reference to the specific fields of application there are different series of unique Bronkhorst proportional, electromagnetic control valves.

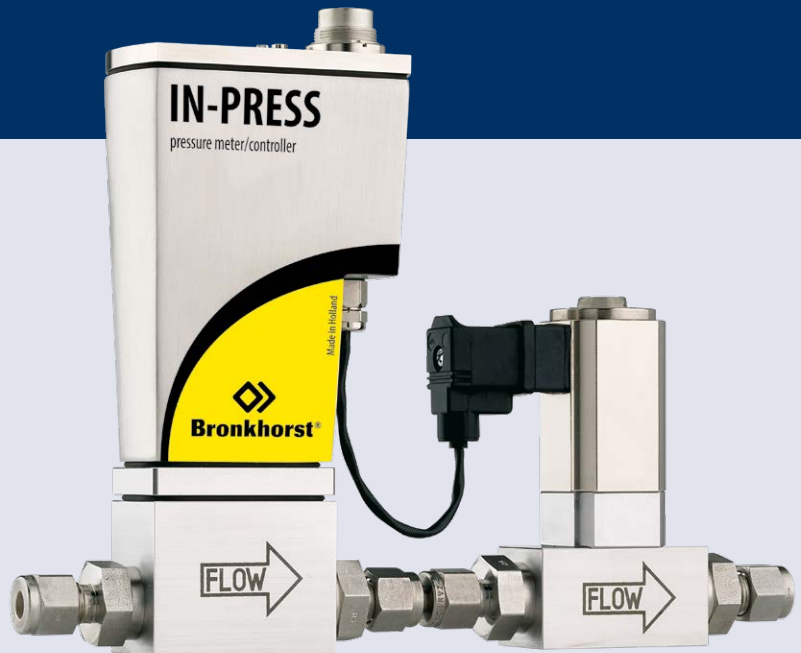

There is a standard direct acting valve for common applications, a pilot operated valve for high flow rates, the so-called Vary-P valve that can cope with up to 400 bar ΔP and a bellows valve for applications with very low differential pressure.

> General IN-PRESS features

- ◆ Weatherproof IP65 housing
- ◆ High accuracy and repeatability
- ◆ High pressure capability up to 400 bar
- ◆ Stable control even at varying process volumes
- ◆ Optional: ATEX approval Cat.3, Zone 2
- ◆ Analog I/O signals: 0...5(10) V / 0(4)...20 mA
- ◆ Digital communication: RS232, DeviceNet™, PROFIBUS DP, Modbus-RTU/ASCII or FLOW-BUS

> Fields of application

- ◆ Process pressure control in food, pharma and (petro-) chemical industries
- ◆ Fermenter pressure control (Biotechnology)
- ◆ Fuel Cell technology
- ◆ Protective gas pressure control in extrusion moulding processes

> Measuring principle

The Bronkhorst® IN-PRESS pressure sensor is a piezoresistive bridge on the surface of a silicon chip. This chip is drilled out on its reverse side, giving the inside of the chip the form of a pressure diaphragm, whose thickness determines the pressure range. When a pressure acts on this chip, the diaphragm flexes, and the resistor values of the bridge alter in proportion to the pressure. The measuring cell is separated from the external pressure by a thin, sensitive stainless steel diaphragm, and the sealed off cavity between diaphragm and cell is filled with oil.

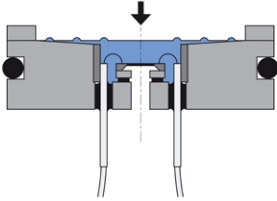

Cross sectional drawing of a pressure sensor

> Dimensional drawings

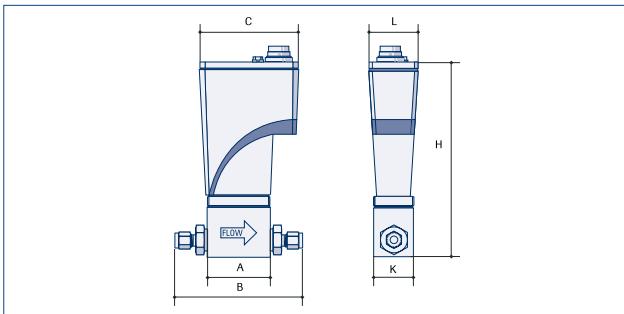

IP65 Pressure Meter

Model	A	B	C	H	K	L	Weight (kg)
P-502CI/P-512CI/ P-522CI/P-532CI (1/4")	47	104	74	145	30	36	1.1

Dimensions in mm.

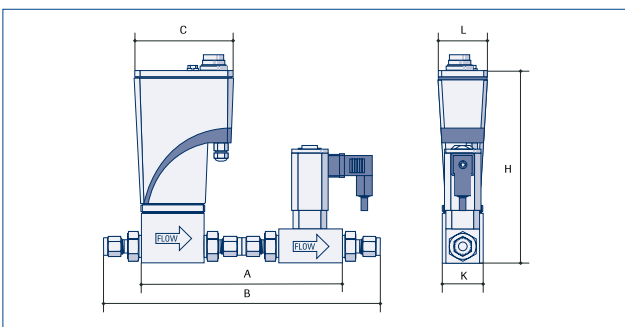

IP65 Forward or Back Pressure Controller

Model	A	B	C	H	K	L	Weight (kg)
P-502CI+F-001AI/ P-512CI+F-011AI (1/4")	150	207	74	145	30	36	1.6

Dimensions in mm.

> Configurations

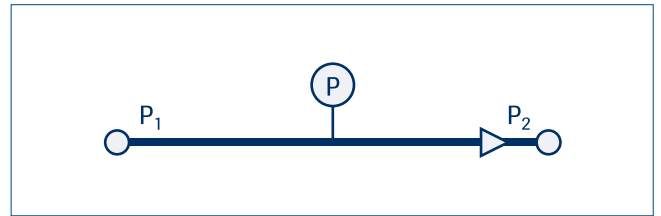

Pressure measurement

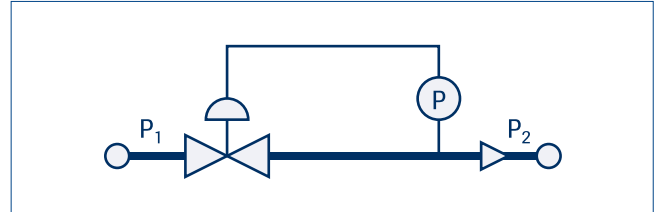

Forward pressure control

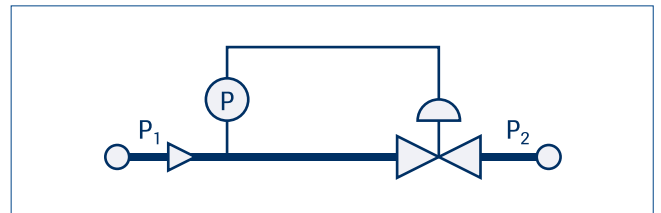

Back pressure control



P-502CI Pressure Meter

> Examples of some applications

It is of course impossible to picture the possible number of applications. Here is a limited quantity of basic examples, which are often seen with some variations. However, identical or similar configurations are used in totally different applications. Therefore please consider the ones pictured here as examples for solving common applications.

> Pressure control with adjustable flow

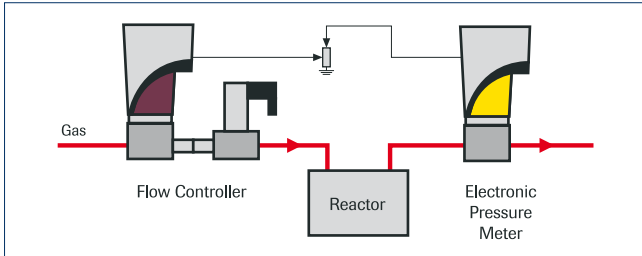

The control valve of the IN-FLOW Mass Flow Controller (MFC) forms a closed loop pressure control system with the IN-PRESS Pressure Transducer: the Mass Flow Meter of the MFC measures the required flow rate to maintain the set pressure level. The set-point voltage divider enables the user to adjust the maximum flow to build up desired pressure levels. Restriction of the maximum flow may for safety reasons be important in certain processes.

> Compensation of atmospheric pressure changes

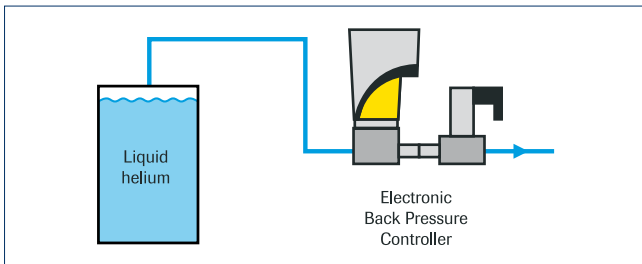

Superconducting coils, which are used to generate magnetic fields, are cooled by liquid helium. Depending on the temperature exchange gaseous helium should be vented. With a manually controlled outlet the variation of the atmospheric pressure disturbs the magnetic field. By using an IN-PRESS Back Pressure Controller the pressure for the superconducting coils is kept constant, thus eliminating the negative effects of atmospheric pressure variations.

> Back pressure control independent of gas mix and total flow

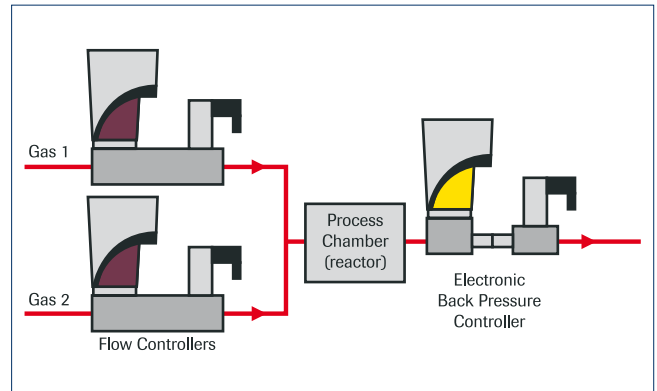

A gas mixture is formed by IN-FLOW Mass Flow Controllers. In a process chamber the effect of the catalyst on certain reactions is tested. The pressure in the process chamber is controlled to the desired level by means of an IN-PRESS Back Pressure Controller, independent of the total flow and/or the composition of the mixture.

> Pressure control combined with flow measurement

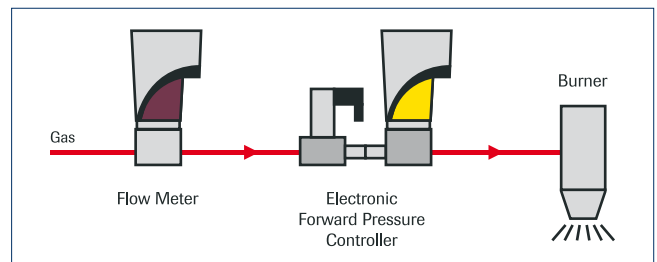

This arrangement of an IN-FLOW Mass Flow Meter with, in series, an IN-PRESS Forward Pressure Controller is used in burner test applications, or tests to check the inlet pressure dependence of the capacity of mechanical pressure regulators, or the tolerance on the bore of orifices, etc.

> Back Pressure Control in Fuel Cell Systems

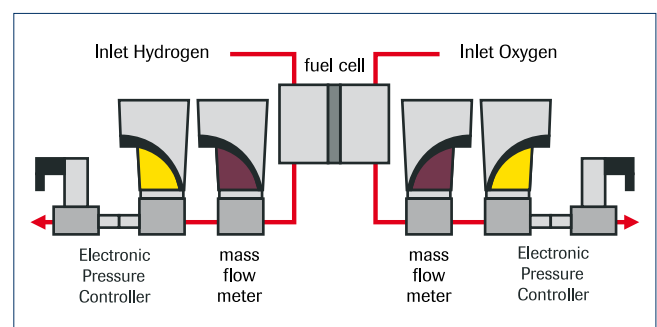

In Fuel Cell systems Electronic Pressure Controllers are used to maintain the pressure at optimum process conditions, even at variable flow rates. The IN-PRESS Back Pressure Controllers keep the H₂ and O₂ pressures equal and very stable, ensuring that the membranes of the cells are not damaged by large pressure differences.

> Technical specifications

Measurement / control system

Accuracy (incl. linearity and hysteresis)	: ±0,5% of full scale (FS)
Pressure rangeability	: measurement: 1 : 50 (2 ... 100%) control (with flow range 1 : 50) backpressure control: 1 : 5 forward pressure control: 1 : 20
Repeatability	: ≤ 0,1% RD
Response time sensor	: 2 msec
Control stability	: ≤ ±0,05% FS (typical for 1 l _v /min N ₂ at specified process volume)
Operating temperature	: -10...+70°C; for ATEX Cat. 3: 0...50°C
Temperature sensitivity	: 0,1% FS/°C
Leak integrity	: tested < 2 x 10 ⁻⁹ mbar l/s He
Attitude sensitivity (at 90° change)	: < 0,3 mbar
Warm-up time	: negligible

Mechanical parts

Material (wetted parts)	: stainless steel 316L or comparable
Process connections	: compression type or face seal couplings
Seals	: standard: Viton® options: EPDM, Kalrez® (FFKM)
Ingress protection (housing)	: IP65

Electrical properties

Power supply	: +15...24 Vdc		
Max. power consumption:	Supply	at voltage	I/O at current I/O
	Meter:	15 V	67 mA 90 mA
		24 V	49 mA 67 mA
	Controller:	15 V	200 mA 223 mA
		24 V	132 mA 150 mA
Extra for fieldbus: (if applicable)	PROFIBUS DP:	add 53 mA (at 15 V) or 30 mA (at 24 V)	
	DeviceNet™:	add 48 mA (at 24 V)	
Analog output/command	: 0...5 (10) Vdc or 0 (4)...20 mA, min. load impedance > 2 kOhm; 0 (4)...20 mA (sourcing output), max. load impedance < 375 Ohm		
Digital communication			
Standard (8 DIN male)	: RS232		
By optional interface board	: PROFIBUS DP, DeviceNet™, FLOW-BUS, Modbus-RTU/ASCII		
Electrical connection			
Analog/RS232	: 8 DIN male		
PROFIBUS DP	: bus: 5-pin M12 female; power: 8 DIN male		
DeviceNet™	: 5-pin M12 male		
FLOW-BUS/Modbus-RTU/ASCII	: 5-pin M12 male		

Calibration

References verified by an ISO 17025 calibration laboratory, directly traceable to Dutch and international standards.

Technical specifications subject to change without notice.

> Models and pressure ranges

Electronic Pressure Transducers (EPT)

Models	Pressure ranges (abs/rel)	
P-502CI	min. 2...100 mbar	max. 1,28...64 bar
P-512CI		max. 2...100 bar
P-522CI		max. 4...200 bar
P-532CI		max. 8...400 bar

Electronic Pressure Controllers (EPC)

Models	Pressure ranges (abs/rel)	
P-502CI + F-001AI ¹⁾ (back pressure control)	min. 20...100 mbar	max. 12,8...64 bar
F-001AI ¹⁾ + P-502CI (forward pressure control)	min. 5...100 mbar	max. 3,2...64 bar

¹⁾ Separate control valve with $K_v\text{-max} = 6,6 \times 10^{-2}$

For ranges of 100, 200 or 400 bar rated pressure controllers and for low-ΔP applications with K_v -values up to 1.0 please contact factory.

> Model number identification

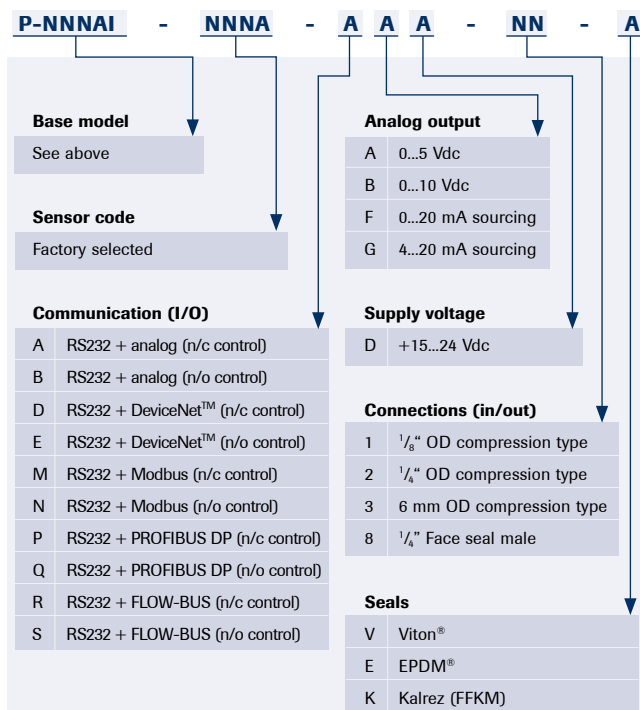

Bronkhorst®