

# MASS VIEW

The intelligent alternative for VA meters: mass flow meters for gases with flow display

## > Introduction

Bronkhorst High-Tech B.V., the European market leader in thermal Mass Flow Meters/Controllers and Electronic Pressure Controllers, has many years of experience in designing and manufacturing precise and reliable measurement and control devices. With a wide range of instruments, Bronkhorst High-Tech offers innovative solutions for many different applications in a variety of different markets.

## > Description

This new series of mass flow meters provides modern, novel and economical alternative to variable area meters (VA meters), also known as rotameters or purgemeters. Unlike conventional VA meters this new flow meter measures mass flow instead of volume flow. For easy VA meter replacement the MASS-VIEW®'s mechanical construction offers the most common options for process connection on the market.

## > MASS-VIEW® series thermal mass flow meters

Bronkhorst High-Tech designed MASS-VIEW® series operate on the principle of direct thermal mass flow measurement (no by-pass). An advantage of using this type of sensor is that the instrument measures direct mass flow, without the need of temperature and pressure correction. Other benefits, compared to conventional VA meters are higher accuracy, wider rangeability (up to 1:100), free of parallax errors and an inherently safer construction, by eliminating glass components in the flow path. MASS-VIEW® flow meters can be supplied in full scale ranges from 0.2 up to 200 l<sub>n</sub>/min (Air equivalent), with a pressure rating of 10 bar(g) or 150 psi(g). A bright graphical OLED display, clearly visible at wide angles, allows reading of actual flow (value and a bar graph), total flow and type of gas. The display features easy set up via a user-friendly menu, using a 4-way navigation push button. The pre-installed gases eliminate the need to recalibrate for different gases and therefore reduce the cost of ownership. Additional features & functions include a variety of alarm and counter functions, an analog output signal, digital interfaces and two relay contacts. Flow control may be achieved with an optional needle valve. These high quality needle valves offer smooth and fine adjustment of the gas flow rates.

## > MASS-VIEW® features

- ◆ Clear indication in:
  - Actual flow rate (bar graph and value)
  - desired flow units
  - type of gas
  - totalized flow
- ◆ Bright, wide-angle OLED display
- ◆ Free of parallax errors
- ◆ Virtually independent of pressure and temperature variations
- ◆ Low pressure drop
- ◆ Wide flow ranges
- ◆ Fast response
- ◆ High accuracy
- ◆ Electronic output, analog (0...5 Vdc) and digital interface

## > Digital features

- ◆ RS232 interface and Modbus ASCII/RTU communication
- ◆ Configurable password protection
- ◆ Alarm and counter functions
- ◆ Multi Gas / Multi Range
- ◆ Pre-installed gases
- ◆ Digitally calibrated
- ◆ Free Bronkhorst software tools



## > Technical specifications

Performance	
Accuracy	: ± 2% RD for flow > 50% of max. capacity; ± (1% RD + 0.5% FS) on lower flows
Repeatability	: < 0.1% FS typical
Pre-installed gases	: Air, Ar, N <sub>2</sub> , O <sub>2</sub> , CO <sub>2</sub> , CH <sub>4</sub> , C <sub>3</sub> H <sub>8</sub> , N <sub>2</sub> O, CO and C <sub>4</sub> H <sub>10</sub> (special models available for H <sub>2</sub> and Helium)
Standard calibration gas	: Air, other gases are converted using our Fluidat® conversion model which will introduce extra inaccuracy
Rangeability	: up to 1:100
Operating pressure	: 0...10 bar(g) / 0...150 psi(g)
Pressure coefficient	: 0.2%/bar typical at Air
Operating temperature	: 0...50°C (32...122°F)
Temperature coefficient	: Zero: <0.1%FS/°C, Span: <0.2%RD/°C
Attitude sensitivity	: < 0.1%FS
Response time (t <sub>63%</sub> )	: 2 s
Mechanical specifications	
Materials (wetted parts)	: Meter: aluminium, Viton Needle valve: SS316, viton, PTFE; for models MV-3x2: Fluorosint®, Brass en Buna N
Gas connections (in/out)	: G 1/4" BSP female thread (compression fittings optional)
Weight	: 0.7 kg
Electrical specifications	
Electrical connection	: 8-pin RJ-45 modular jack
Output	: analog: 0...5 Vdc digital: RS232 / RS485 (Modbus ASCII/RTU)
Required supply voltage	: 15...24 Vdc (+/-10%)
Power consumption	: approx. 135 mA
Min. and max. relay contacts	: switching current 0.5 A, 24 Vdc, one side grounded (0 Vdc power)
Safety	
Test pressure	: 21 bar (a) / 300 psi (a)
Ingress protection	: IP-50
Leak integrity (outboard)	: < 1 x 10 <sup>-9</sup> mbar l/s He
EMC	: CE declaration
Warranty	
All instruments and accessories are warranted for a period of 3 years from order date.	

## > Capacities

Selectable ranges in l <sub>r</sub> /min (SLM)	Air	N <sub>2</sub>	O <sub>2</sub>	CO	Ar	CO <sub>2</sub>	CH <sub>4</sub>	C <sub>3</sub> H <sub>8</sub>	N <sub>2</sub> O	C <sub>4</sub> H <sub>10</sub>
<b>MV-102 and MV-302</b>										
Range 1 (max.)	0.02...2	0.02...2	0.02...2	0.02...2	0.04...4	0.02...2	0.01...1	0.01...1	0.02...2	0.01...1
Range 2	0.01...1	0.01...1	0.01...1	0.01...1	0.02...2	0.01...1	0.005...0.5	0.005...0.5	0.01...1	0.005...0.5
Range 3	0.01...0.5	0.01...0.5	0.01...0.5	0.01...0.5	0.02...1	0.01...0.5	0.005...0.2	0.005...0.2	0.01...0.5	0.005...0.2
Range 4 (min.)	0.01...0.2	0.01...0.2	0.01...0.2	0.01...0.2	0.02...0.5	0.01...0.2	0.005...0.1	0.005...0.1	0.01...0.2	0.005...0.1
<b>MV-104 and MV-304</b>										
Range 1 (max.)	0.2...20	0.2...20	0.2...20	0.2...20	0.4...40	0.2...20	0.1...10	0.1...10	0.2...20	0.1...10
Range 2	0.1...10	0.1...10	0.1...10	0.1...10	0.2...20	0.1...10	0.05...5	0.05...5	0.1...10	0.05...5
Range 3	0.05...5	0.05...5	0.05...5	0.05...5	0.1...10	0.05...5	0.02...2	0.02...2	0.05...5	0.02...2
Range 4 (min.)	0.04...2	0.04...2	0.04...2	0.04...2	0.08...5	0.04...2	0.02...1	0.02...1	0.04...2	0.02...1
<b>MV-106 and MV-306</b>										
Range 1 (max.)	2...200	2...200	2...200	2...200	4...400	2...200	1...100	1...100	2...200	1...100
Range 2	1...100	1...100	1...100	1...100	2...200	1...100	0.5...50	0.5...50	1...100	0.5...50
Range 3	0.5...50	0.5...50	0.5...50	0.5...50	1...100	0.5...50	0.2...20	0.2...20	0.5...50	0.2...20
Range 4 (min.)	0.4...20	0.4...20	0.4...20	0.4...20	0.8...50	0.4...20	0.2...10	0.2...10	0.4...20	0.2...10

## > Models and flow capacities

Model	Description	Max. capacity
	(relative Air)	
MV-102	MASS-VIEW® meter	2 l <sub>r</sub> /min (SLM)
MV-104	MASS-VIEW® meter	20 l <sub>r</sub> /min (SLM)
MV-106	MASS-VIEW® meter	200 l <sub>r</sub> /min (SLM)
MV-302	MASS-VIEW® meter with needle valve	2 l <sub>r</sub> /min (SLM)
MV-304	MASS-VIEW® meter with needle valve	20 l <sub>r</sub> /min (SLM)
MV-306	MASS-VIEW® meter with needle valve	200 l <sub>r</sub> /min (SLM)
MV-192-He	MASS-VIEW® meter	2 l <sub>r</sub> /min (SLM)
MV-194-He	MASS-VIEW® meter	20 l <sub>r</sub> /min (SLM)
MV-196-He	MASS-VIEW® meter	100 l <sub>r</sub> /min (SLM)
MV-192-H2	MASS-VIEW® meter	1 l <sub>r</sub> /min (SLM)
MV-194-H2	MASS-VIEW® meter	10 l <sub>r</sub> /min (SLM)
MV-196-H2	MASS-VIEW® meter	100 l <sub>r</sub> /min (SLM)
MV-392-He	MASS-VIEW® meter with needle valve	2 l <sub>r</sub> /min (SLM)
MV-394-He	MASS-VIEW® meter with needle valve	20 l <sub>r</sub> /min (SLM)
MV-396-He	MASS-VIEW® meter with needle valve	100 l <sub>r</sub> /min (SLM)
MV-392-H2	MASS-VIEW® meter with needle valve	1 l <sub>r</sub> /min (SLM)
MV-394-H2	MASS-VIEW® meter with needle valve	10 l <sub>r</sub> /min (SLM)
MV-396-H2	MASS-VIEW® meter with needle valve	100 l <sub>r</sub> /min (SLM)

### Notes:

- Mass flow units l<sub>r</sub>/min and SLM refer to normal operating conditions, i.e. 0°C (32°F) and 1013 mbar (14.7 psi)
- Technical specifications are based on Air at maximum FS
- All specifications subject to change without notice

## > Dimensions

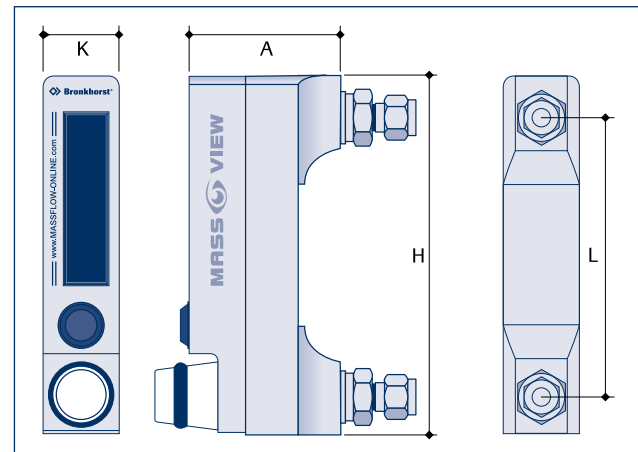

Model	A	H	K	L
MV-102/104/106/192/194/196	63	159	38	114
MV-302/304/306/392/394/396	63	159	38	114

Dimensions in mm.

## > Electrical connection

### Hook-up diagram

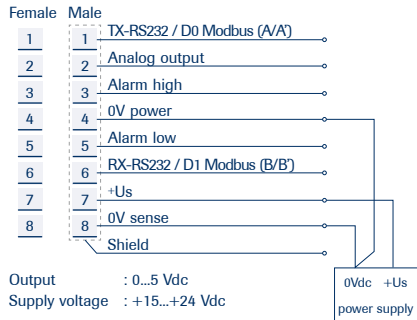

**Note:** 0V power (pin 4) and 0V sense (pin 8) should be separately connected to the 0V terminal at the power supply

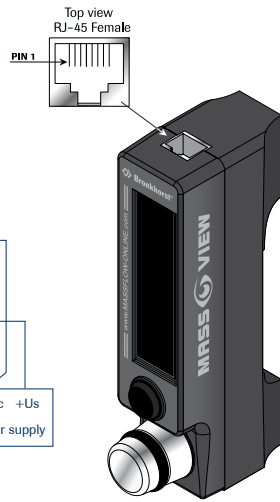

## > Accessories

Following accessories are offered as an option for the MASS-VIEW® instruments.

### Adapter sets (inlet and outlet)

Metric sizes	Inch sizes
3 mm OD compression type	1/8" OD compression type
6 mm OD compression type	1/4" OD compression type
12 mm OD compression type	1/2" OD compression type

### Power supply and electrical connection

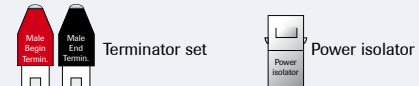
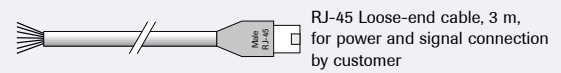
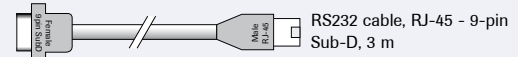
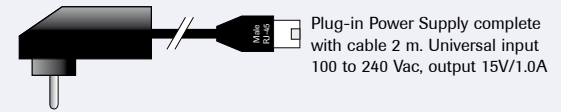
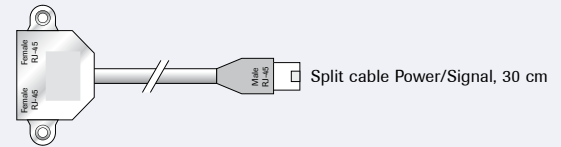
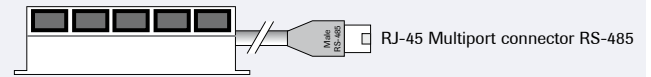

## > Cabling options

Combinations for separate connection of power and I/O signals.

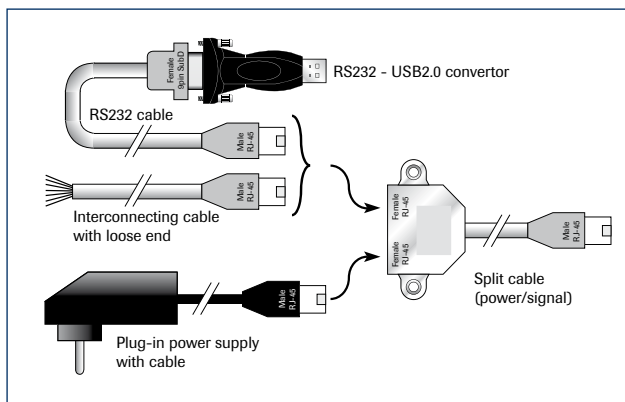

## > Cabling example

Example for 7 MASS-VIEW meters/regulators with RS485 - USB signal connection. Two separated power networks are required due to the maximum power supply of 15 Watt for one PIPS-MV.

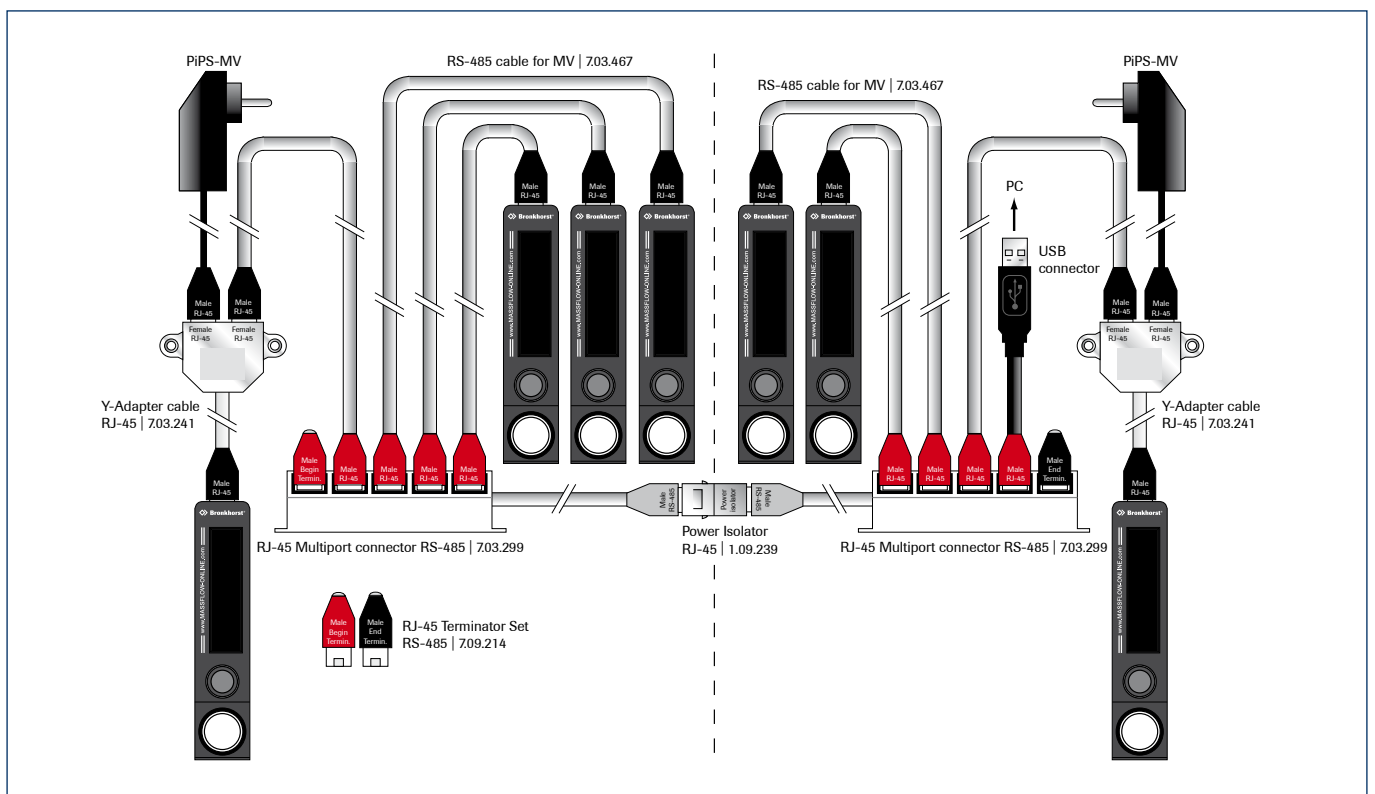

## > Applications

The fields of application for MASS-VIEW® are diverse:

- ◆ Burner control (furnace construction)
- ◆ Welding (welding gas monitoring)
- ◆ Leak measurements (quality, environment)
- ◆ Coating (equipment construction)
- ◆ Regulation of gaseous atmospheres (biotechnology)
- ◆ Measurement of gas consumption (hospitals)
- ◆ Test equipment (production maintenance)
- ◆ Local preparation of a gas mixture
- ◆ Flow rate monitoring (laboratories)
- ◆ Cutting (steel sheets)
- ◆ Cost centre billing
- ◆ Analytical equipment
- ◆ Aeration / sparging (food products, ice cream / edible oils)
- ◆ Blanketing (food)
- ◆ Fermentation (food, biotechnology, pharma)



MASS-VIEW® Mass Flow Meter

## > Display menu

The 4-way navigation push button provides access to a user-friendly menu, e.g. for zero function, for selection of pre-installed gases in pre-installed capacities, setting of engineering units, alarm functions (minimum/maximum/counter limit) and counter functions. Password protection is provided to prevent unauthorized changes. Below overview of the MASS-VIEW® menu functions illustrates the great versatility of this product line.

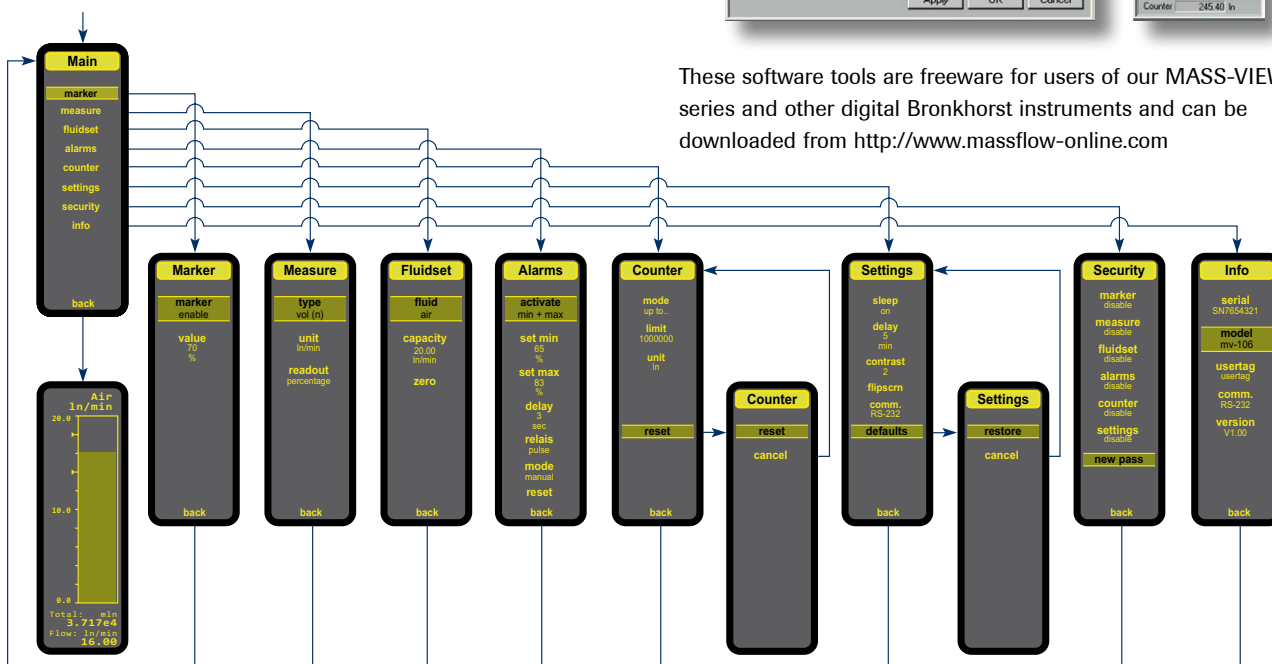

## > Bronkhorst FlowWare, free software tools

Bronkhorst High-Tech offers following software support for installation and operation by personal computer:

**FlowDDE** : Software tool to interface between digital instruments and MS Windows software.

**FlowPlot** : Software tool for monitoring and optimizing digital instruments parameters.

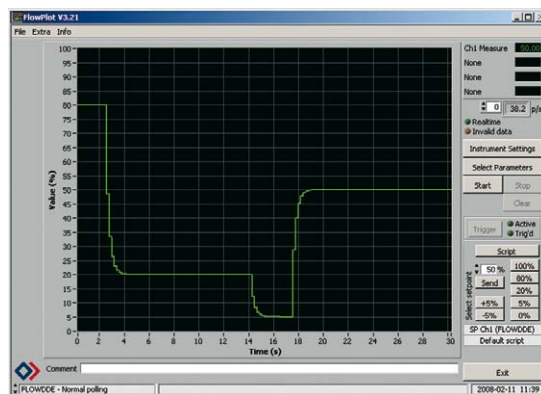

**FlowView** : Software tool to operate Bronkhorst digital instruments.

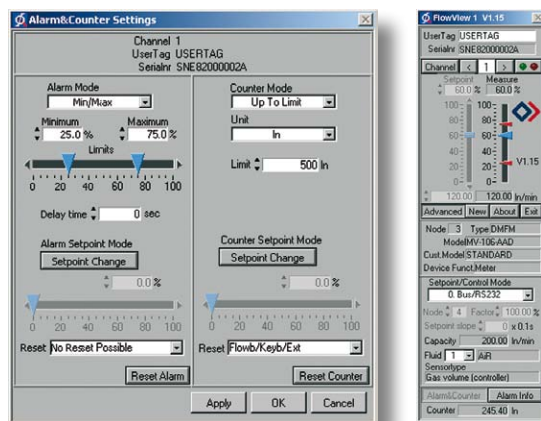

These software tools are freeware for users of our MASS-VIEW® series and other digital Bronkhorst instruments and can be downloaded from <http://www.massflow-online.com>